



SCIENTISTS
IN SCHOOL
SCIENTIFIQUES
À L'ÉCOLE

Teacher Resource Package



Let us help you piece together the science!

Background Information an overview of the topic and theoretical concepts.

Hands-on Activities

Activity 1 - pen/paper activity

Activity 2 - short, easy-to-do activity (30-60min)

Activity 3 - short, easy-to-do activity (30-60min)

Activity 4 - longer activity (greater than 1 hr)

Activity 5 - complex activity

Teacher Resources

Literary Resources

Website Resources

Interactive White Board Resources

Multi-media

Student Resources

Literary Resources

Interactive Websites

Please help us improve our teacher resource packages!

If you have any feedback about this package or suggestions for new resources to include, please don't hesitate to contact us at: inquiries@scientistsinschool.ca.

Structures: Stable and Strong

Have you asked your students if they made or used a structure today? Perhaps they created a bridge by laying a branch across a stream or rode their bicycle to get to school. We use structures everyday. They surround us in our community but we may not always take notice of them. Did you notice that bridge on the drive to school or the hydro towers nearby? Have you ever wondered if the bridge that you cross is really strong and stable? What went into designing and constructing this essential structure? There are many professionals involved in designing and building structures such as engineers, architects and builders. They play an important role in making a structure safe and useful for us.

Background Information

Structures

A structure is an object with a definite size and shape that is constructed for a specific function or purpose. In order to serve its purpose, the structure must be strong, stable and it must be able to hold a load. If a structure is going to be useful, then it must be able to withstand forces. There are many types of structures that are found in nature such as mountains, bee hives and icebergs. There are also human made structures such as towers, flag poles and automobiles.

Materials

Each material used in a structure has specific characteristics and properties. Engineers will look for materials with certain properties to ensure their structure meets the requirements of its purpose. Structural strength is one of the most important properties to consider. The strength of a material can be further improved by layering, braiding, twisting and changing the shape of the material. Engineered hardwood is comprised of layers of different wood in opposite directions that provides strength as well as resistance to humidity. Another way to increase strength is to combine two or more different materials to create a stronger composite material. Steel bars can be used within concrete to reinforce it, resulting in a stronger building material. Carbon or glass fibres can be combined with resin to create a strong yet lightweight composite material. These fibre-reinforced polymers are commonly used in high performance automobiles and boats as well as in the aerospace and aviation industries.

Other properties that might be considered when making a structure for a specific purpose are flexibility, absorbency, durability and thermal resistance. A combination of materials with different properties can also be used to improve a structure's usefulness. For example, a roof has many layers to fulfill its purpose of providing shelter, being weather resistant and supporting a load. The materials utilized in a roof which make it strong, durable and water repellent include a wood frame, plywood, tar paper and shingles. The way different materials are used in construction and the design of objects will ultimately determine the strength and effectiveness of the structure.

Forces

When a load is applied to a structure, there are forces that act upon the structure:

- a structure is under tension when there are pulling or stretching forces acting on it (e.g. stretching a rubber band);
- a structure is under compression when there are pushing or squeezing forces acting on it (e.g. squishing a sponge).

The materials used in structures will resist tension and compression differently depending on their characteristics. Wood, commonly used in construction, is a good example of a material that can resist both forces. A material that is particularly strong at resisting tension due to its elastic properties is steel. Concrete is strong at resisting compression but not tension as it is non-elastic.

A structure that is pushed to its stretching or tensile limit will fail by snapping. In contrast, buckling will occur when a structure fails under compression. The structural design and the use of specific building materials can transfer and dissipate these powerful forces. By combining materials, engineers are able to change their properties. The use of steel within concrete can improve the tensile and compressive properties of these materials.

Strength and Stability

Strength is the ability to support a load and withstand forces. Stability is the ability to maintain balance without snapping and collapsing. The strength and stability of a structure is dependent on whether it has been designed to withstand forces by transferring them from weak to strong areas. Engineers employ many different structural design techniques to improve strength and stability. These can include:

- beam – a structural component that is used to support a load across its span which resists bending or the tension and compression forces within it (e.g. reinforced concrete beam).
- truss – a structural component that uses triangles (a strong, stable shape) to bear large loads and prevent deformation of the structure. There are two parts of a truss system:
 - a) a strut is a support element in a truss that resists compression and stops the structure from being pushed together (e.g. wing strut on an airplane);
 - b) a tie is a support element in a truss that resists tension and stops the structure from being pulled apart (e.g. rafter tie on a roof).
- arch – a semi circular shape that resists compression by transferring forces to the supports on each side of the arch, called abutments (e.g. bridge).
- column – a structural component that resists compression and supports the weight above (e.g. Roman Parthenon).
- centre of gravity – the place in a structure where the weight is evenly dispersed and all sides are in balance. This is an important element to locate in a structure to ensure the structure is stable and able to withstand forces. The centre of gravity can be shifted lower by building a wide and solid base (e.g. skyscraper to withstand strong winds).
- flexibility – an element to consider when designing a structure that allows for movement without snapping or collapsing as a result of forces (e.g. a bridge in an earthquake zone).

Many of these techniques were utilized in ancient civilizations as early as 2000 years ago. Stone arch bridges were built without mortar and many still stand today. As time progressed, engineers have applied new techniques to build larger structures. Skyscrapers were made possible by two inventions: the use of *steel frames* in construction in addition to walls for support; and the *elevator* which was first built in New York in 1857. The father of the skyscraper was the original 10-storey Home Insurance Building in Chicago built in 1884. It was the first design to use skeleton or steel frame technology. Today, we continue to push the limits with modern complex structures that either span longer distances or extend as larger and taller structures. The world's longest bridge, Akashi Kaikyo Bridge in Japan, is a suspension bridge completed in 1998. It has a span of 1990 m (6530 ft) and is supported by steel cables anchored to concrete towers.

The Environment

The environment becomes an increasingly important consideration when designing a structure. Engineers have to determine if the natural environment can support it, and if not, what needs to be done to make it not only strong and stable but also sustainable. Materials used in structures come from finite natural resources. Engineers must understand the environmental consequences of building structures and look for ways to reduce their impact such as salvaging and recycling materials, using alternative materials and improving the life cycle of structures.

Activity 1: Span Your Bridge Knowledge!

Time: 30-60 minutes

Other Application:
Language

Key Terms: tension, compression, forces, struts, ties, arches, beams

Group Size: Individual

Materials:

- "Span your Bridge Knowledge!" worksheet (part 1 & 2)
- pencil

Learning Goal: Students will learn about different bridge types and the forces that act upon them.

There are 4 main types of bridges that mainly differ in the distance they can cross in a single span.

- **Beam Bridge** - The simplest bridge is the beam bridge which consists of a horizontal beam, or a deck, supported by piers.
- **Truss Bridge** - A truss bridge is like a beam bridge with a brace. It consists of an assembly of triangles to provide extra support and rigidity.
- **Suspension Bridge** - A suspension bridge is held by ropes or cables (ties) from tall towers. Most suspension bridges have a truss system built in to allow it to resist bending and twisting.
- **Arch Bridge** - The arch bridge uses a semi-circular shape to provide support. The abutments, or retaining walls, on the sides of the bridge will directly take on the pressure exerted by the load.

The following websites have great visual examples of these types of bridges: <http://www.pbs.org/wgbh/buildingbig/bridge/basics.html> (11/06/15); <http://www.pbs.org/wgbh/nova/tech/build-bridge-p3.html>(11/06/15).

Procedure:

1. Provide a copy of "Span your Bridge Knowledge!" worksheet (part 1 & 2) to each student.

Part 1: Types of Bridges

2. For Part 1, ask students if the bridges are beam, truss, suspension or arch bridges? Have students identify each "Type of Bridge" and label it in the grey box below the corresponding picture.
3. Review the "Advantages" column and have students match the best "Advantage" to the "Type of Bridge" by drawing a line from one of the advantages to the corresponding bridge type.
4. Repeat for the "Disadvantages" column.

Part 2: Parts of Bridges

5. For Part 2, review the parts of a bridge - deck, ties, trusses, piers, pillars and abutments. Have students label the bridge components for each type of bridge by labelling on the dotted lines.

Fun Fact: Cool Canadian Bridge!

The 12.9 km Confederation Bridge joins Prince Edward Island to New Brunswick and is the longest bridge in the world that crosses ice-covered water!

Observations:

The following illustrates a completed worksheet with advantages, disadvantages and labelled components for each type of bridge.

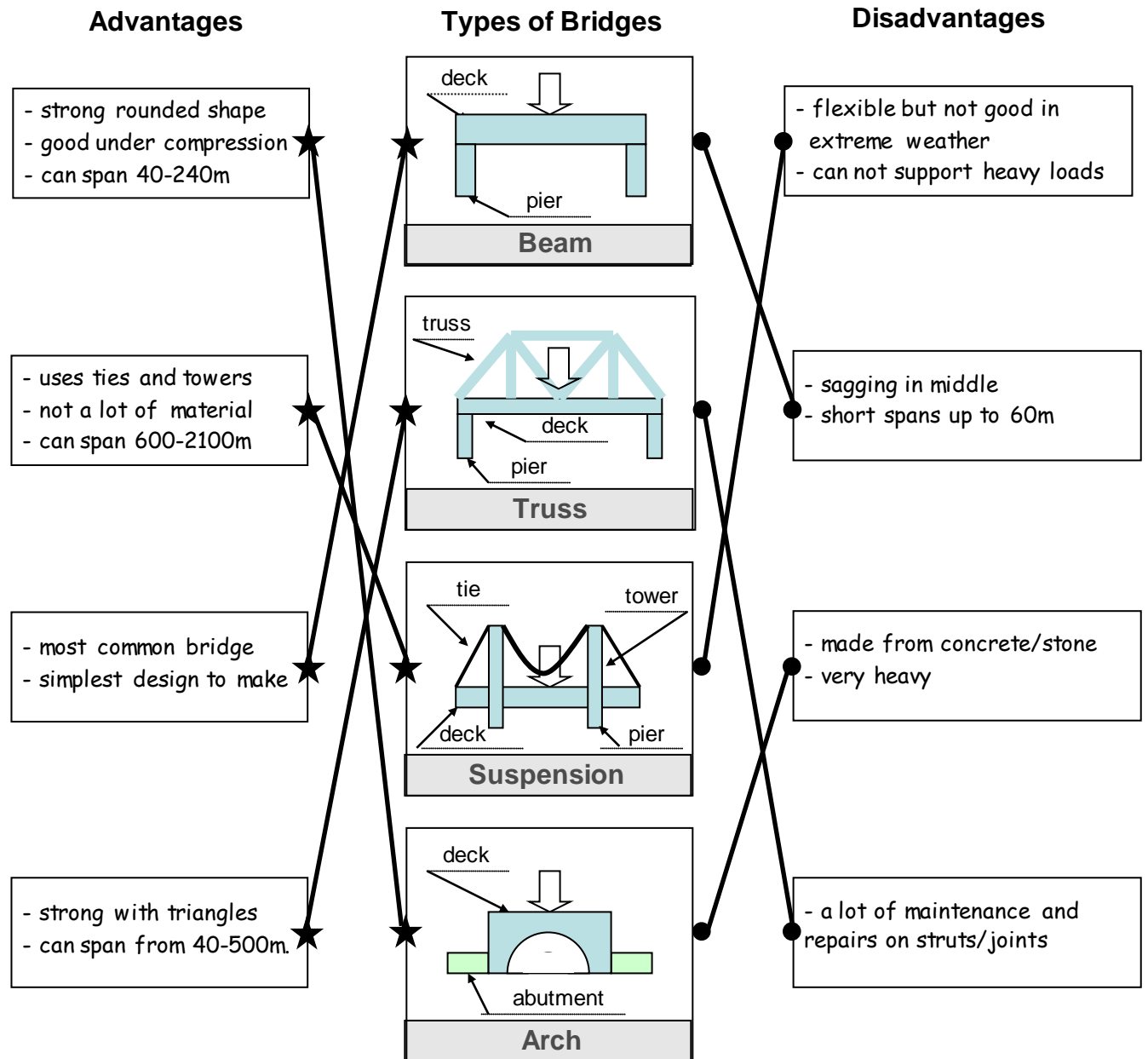

Discussion:

Ask students to identify some local bridges in their community. Discuss with students what bridge type their local bridge might be. Ask students what shapes they see within the bridge structure (triangles, cylinders, rectangular prisms, etc). Discuss the forces that act on the bridge (tension and compression). Compare the forces from the dead load (weight of the bridge itself) and the live load (what it needs to support such as people, cars and trains).

Span Your Bridge Knowledge!

Part 1: Types of Bridges

Advantages

- strong rounded shape ★
- good under compression
- can span 40-240m

- uses ties and towers ★
- not a lot of material
- can span 600-2100m

- most common bridge ★
- simplest design to make

- strong with triangles ★
- can span from 40-500m.

Types of Bridges

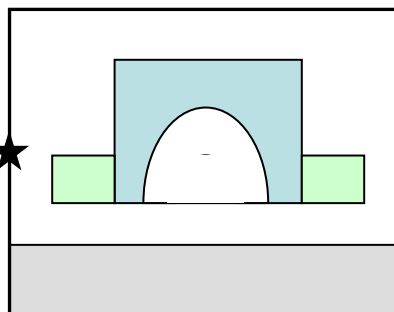
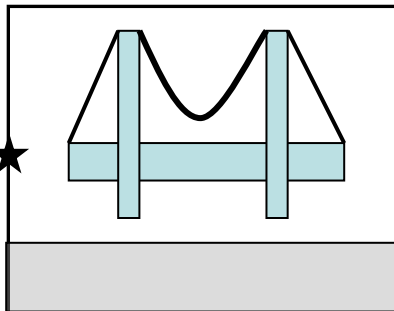
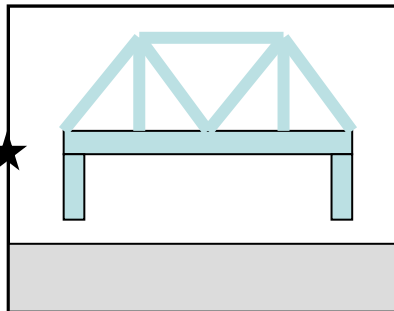
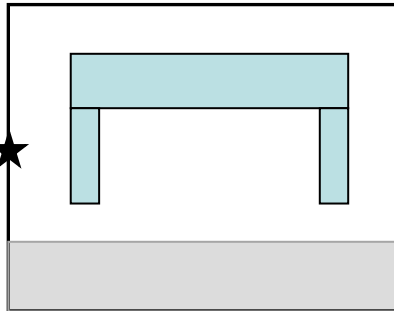

Disadvantages

- - flexible but not good in extreme weather
- - can not support heavy loads

- - sagging in middle
- - short spans up to 60m

- - made from concrete/stone
- - very heavy

- - a lot of maintenance and repairs on struts/joints

Name: _____

Span Your Bridge Knowledge!

Part 2: Bridge Components

Parts of a Bridge: deck, tie, truss, pier, pillar, abutment

 The large arrow illustrates the external load on the bridge.

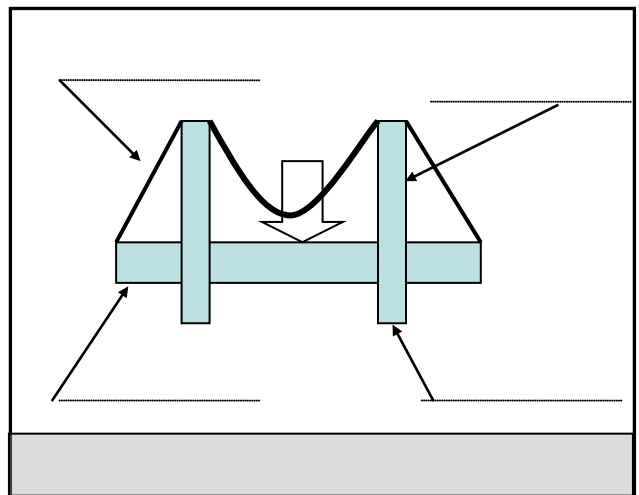
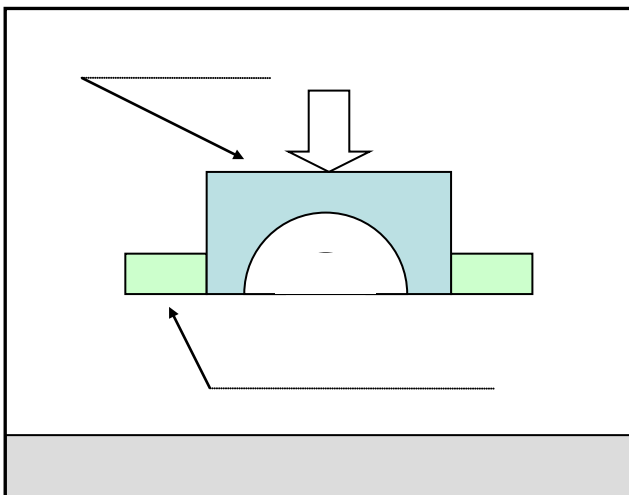
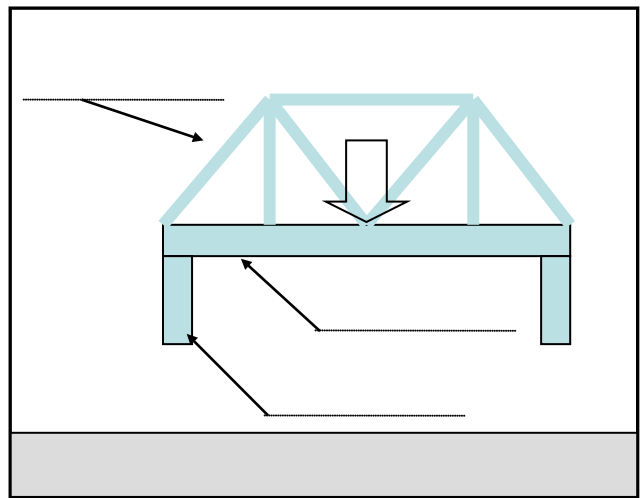
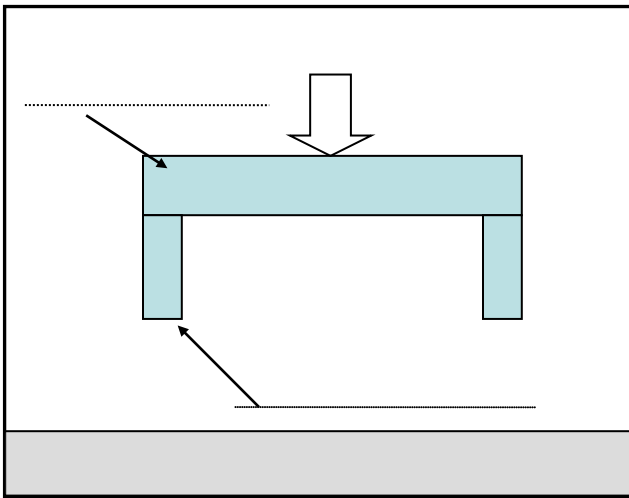

Activity 2: Layer it up!

Time: 60-90 minutes

Other Application: Art,
Language

Key Terms: strength,
material properties, layering,
braiding, forces

Group Size: Small groups
(2 students)

Materials per group:

- 4 straight plastic straws
(without bendable part)
- materials to stuff into
straws (e.g. pencil, paper,
cotton, string)
- 20 cm piece of string
- paper clip
- 4 strips of 8 cm wide
plastic food wrap
- tape

Learning Goal: Students will learn about different materials and investigate whether they can make them stronger.

The properties of a material can differ just by changing its shape. A sheet of newspaper has different properties than a rolled up newspaper. The strength of a structure can be improved by using different design techniques, such as layering, braiding, twisting and changing the shape of the materials used.

Procedure:

1. Design a fishing rod using one straw, tape, string and a paper clip for the hook.
 - a. Add a load (such as tape, eraser, etc.) at the end of the string and observe what happens.
 - b. Ask students to consider what they can do to strengthen their fishing rod. They may try attaching more straws together (layering) or adding different reinforcing materials inside of the straw like a pencil or paper. Have students try the load again to test if they built an improved fishing rod.



2. Design a strong method to hold two or more pencils using plastic wrap.
 - a. Provide students with a strip of plastic wrap and have students attach two or more pencils using the one piece of plastic wrap. The wrap does not have to fully enclose the pencils. Ask students to test the strength of the plastic wrap by pulling the pencils apart.
 - b. Provide students with three additional 8 cm wide strips of plastic wrap and ask the students to design a way to hold pencils together using the strips of plastic wrap. Ask them to consider techniques to make the materials stronger.
 - c. Visit each group to see if they are using common techniques to make their material stronger such as layering, braiding and twisting. Provide them time to redesign.
 - d. Have students pull the pencils apart and feel the force it takes to rip their plastic wrap pencil holder.

Observations:

For each structure they built, students should observe the buckling or snapping of the structure when under tension and/or compression. The fishing rod (straw) will bend and not support the load of an eraser. The plastic wrap will tear and rip easily.

Students should discover that manipulating the materials in different ways will improve the structure. They should observe an improvement on the efficiency of their structure when they strengthen (extra straws on fishing rod), reinforce (pencil inside straw of fishing rod), twist, braid and layer materials (plastic pieces on pencil case).

Discussion:

Discuss with students what forces were involved when their straw fishing rod bent. They should observe a pulling force, tension and compression. What did they do to improve the strength? They layered more straws or reinforced it when they added something inside it.

Discuss with students what they did to make the plastic wrap pencil holder stronger. Did they try layering, braiding or twisting it to improve the strength of the wrap?

Extension:

A possible extension would be to create a Stanley Cup using paper and one using foil. Students will observe the effect of changing the shape of the material as well as the effect of the type of material used. Initially examine and test the strength of a piece of paper and a piece of aluminum foil. Create a mini Stanley Cup by rolling the material into a cylinder shape (layering the material). Twist the material to create a cup shape. Proceed to test the Stanley cup using ice and observe. Which cup handles the environmental conditions of melting ice better?

Fun Fact: Braiding for the Better!

The idea of braiding came from decorating hair which was important for status and traditions in many cultures. It was discovered that if strands of flexible materials, like ropes or wires, were braided together, they made it stronger. Braided ropes were useful, for sailors and rock climbers, since the ropes could support more weight but also because they did not twist like ordinary rope.

Activity 3: Find a Foundation!

Time: 60-90 minutes

Other Application: Math, Language

Key Terms: strength, stability, centre of gravity, forces, load

Group Size: Small groups (2-4 students)

Materials per group:

- "Find a Foundation!" datasheet per student
- 25 wooden toothpicks
- play dough (enough to create a foundation 10 x 10 x 2 cm)
- 2 pieces of 15 x 15 cm cardboard
- large plastic containers
- 8 empty paper coin rolls of similar size (e.g. all dime coin rolls)
- sand, small rocks, rice or beans
- paperback books
- 1 kg masses (e.g. tetra packs, textbooks)

Learning Goal: Students will learn about different types of foundations.

Procedure:

1. Provide students with the goal of making a shallow foundation for a deck.
 - a. Provide a container of wooden toothpicks and play dough. Ask students to flatten the play dough to 1 cm thickness to create the foundation. Place toothpicks (representing columns) upright in the play dough as supports for the deck.
 - b. Place cardboard on top of the wooden toothpick columns to simulate the deck. Test how strong the foundation is by placing paperback books on top of the deck. Count how many books the deck will support before the columns collapse. Record on "Find a Foundation!" datasheet.
 - c. Ask students to remove toothpicks from the play dough.
 - d. Encourage students to come up with ideas to strengthen the foundation. One possibility is that they could create a thicker foundation by compacting the play dough into a ball and flatten it so that it is a thickness of about 2 cm. Place toothpicks upright into the clay again.
 - e. Test the columns again by placing paperback books on top and count how many they can place until the columns collapse. Record and compare results.
2. Provide students with the goal of making a deep foundation for a tall building.
 - a. Provide groups with a plastic container and 4 coin rolls for columns. Place the coin rolls upright in the container. Place cardboard on top to simulate the floor of the building.
 - b. Ask the groups to test out the strength of these paper columns by placing paperback books on the cardboard floor and record how many books they can hold until they collapse.
 - c. Remove the books. Use four new paper coin rolls.
 - d. Encourage students to come up with ideas using "soil" to strength the columns ("soil" can be simulated using materials such as sand, small rocks, rice or beans). An example is to put material around the columns in the container (approx. $\frac{1}{2}$ the height of the columns) and/or material may be used to fill to the top of the coin rolls.
 - e. Have students test how many paperback books the reinforced floor can hold without collapsing. To increase weight, use 1 kg masses (tetra packs, etc.). Record results.

Deck Foundation

(a) 1 cm foundation (b) 2 cm foundation

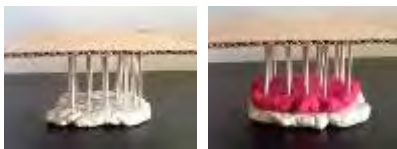

Tall building foundation

Using paper coin rolls and "soil" (rice)



Observations:

The students will discover that when the foundations are deeper, they can support a heavier load. Students will also discover that when the foundations are supported by solid columns, they can support a heavier load. The following represent sample observations. Class observations will vary depending on the weight of the books, quality of the play dough, exact sizes of the foundations and placement of the columns.

Deck Foundation:



The 1 cm deck foundation began to fail after 4 paper back books were loaded on top. The 2 cm deck foundation began to fail after 25 books were loaded.

Tall Building Foundation:



The load was made approximately 10X heavier by using 1 kg tetrapacks instead of paper back books. The tall building foundation failed with paper coin rolls crumpling once the load was 3 kg (approx. 30 books). The foundation was then built in rice (soil) and the columns strengthened by filling them with rice. The foundation could then hold 7 kg (approx. 70 books) and it eventually failed when the columns fell over (rather than crumpling).



Discussion:

Discuss with students their results for the shallow foundation for their deck. Which worked better - the thinner or thicker play dough foundation? Why was it stronger? The thicker foundation held the toothpicks upright longer and therefore was able to support more force applied by the load.

Discuss with students their results for their tall building foundation model, using paper columns and loose material (soil). Initially, when the hollow paper columns were used with no foundation, they failed under the load by crumpling/collapsing. How did the "soil" on the outside help the structure? The soil improved the stability of the structure. The soil helped keep the columns in place and supported the outside of the columns from collapsing. How does soil inside the columns strengthen them? The walls of the columns had additional support and therefore it prevented them from collapsing and crumpling. The columns were also able to help support forces from above. If the foundation was made with something more solid, like soil or concrete instead of rice, the columns would have stayed upright and supported an even larger load.

Discuss how engineers build strong foundations in everyday construction of structures. Foundations are dug deep in the ground to create stronger supports for their structure. Concrete reinforced with steel bars in them will make a strong base for the structure.

Extension:

As an extension, skewers can be used instead of wooden toothpicks to demonstrate the importance of stability of columns. When 25 skewers are used to hold up the deck with the 2 cm foundation, the deck could only hold 7 books before it became unstable (versus 25 with shorter more stable wooden toothpicks). The centre of gravity is higher thus the structure is less stable compared to the short toothpicks. In order to make the set-up with the skewers more stable, the foundation would have to be even deeper to be able to support the taller structure.

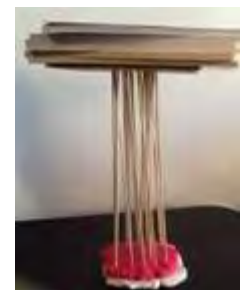

Name: _____

Find a Foundation!

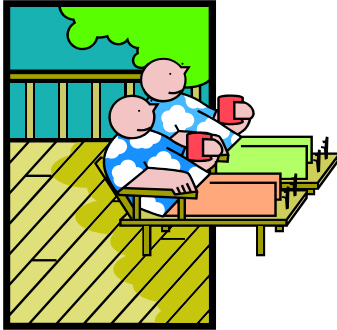

Foundation Design	Load - Number of books held
Thin slab	
Thick slab	

Circle the foundation that held the most books:

Thin

Thick



Foundation Design	Load - Number of books held
No material around foundation	
Material around foundation	

Circle the foundation that held the most books:

No Material

Material

Activity 4: Hold That Water!

Time: 60-90 minutes

Other Application:
Language

Key Terms: strength, stability, load, arch, gravity

Group Size: Small groups (2-4 students)

Materials per group:

- “Hold That Water!” datasheet per student
- 4 recyclable plastic containers (rectangular)
- 6-8 boxboard pieces (cereal/cracker boxes)
- ziplock sandwich bags
- soil/dirt
- sand
- rocks
- small garden/toy shovels
- masking or painter’s tape
- clay
- scissors
- buckets to hold water
- measuring cups

Learning Goal: Students will learn about different types of dams.

Many different styles of dams with different purposes have been developed.

- Arch Dam – This dam is built with a thin concrete wall in the shape of an arch which helps distribute the push of the water against the sides and then into the walls of the valley (abutments). The Hoover Dam in Nevada, USA is a great example of a concrete arch-gravity dam: <http://commons.wikimedia.org/wiki/File:HooverDam.jpg> (11/06/15).
- Buttress Dam – This dam is constructed with a reinforced concrete wall on a slope that is supported by buttresses (generally in a triangular shape) to resist the compressive forces from the water. This dam is useful in wide valleys where there may not be natural rock to support the dam. The Daniel-Johnson dam was constructed for hydroelectric power production in Quebec and is a great example of using a buttress dam. http://commons.wikimedia.org/wiki/File:Barrage_Daniel-Johnson3.jpg?uselang=en-ca (11/06/15)
- Embankment Dam – This dam is constructed with earth and rocks on a slope and has an impermeable layer to keep water from seeping through. These dams are very heavy as well. The Mica Dam in BC is one of the largest earth-filled dams in the world. <http://www.museevirtuel-virtualmuseum.ca/sgc-cms/expositions-exhibitions/hydro/en/dams/?action=mica>(11/06/15)
- Gravity Dam – This dam is built of a thick wall of concrete on a slope. By simply using the weight of the concrete with the force of gravity, the dam is able to resist forces from the push of the water. It must have a strong foundation to ensure it does not slide. The Bhakra Dam in India is one of the highest gravity dams in the world. http://commons.wikimedia.org/wiki/File:Bhakra_Dam_Aug_15_2008.JPG?uselang=en-ca(11/06/15)

Procedure:

1. Ask students to bring in recyclable plastic containers (preferably rectangular in shape) and boxboard (cereal, cracker boxes).
2. Review the different types of dams. Have students complete a drawing of each type of dam on their “Hold That Water!” datasheet.
3. Group students in small groups (2-4 students) and ensure they have 4 containers in each group.
4. Have students line each container with clay along the sides and under where the dam will be built to create a foundation. The group will work together to create a model of each dam.

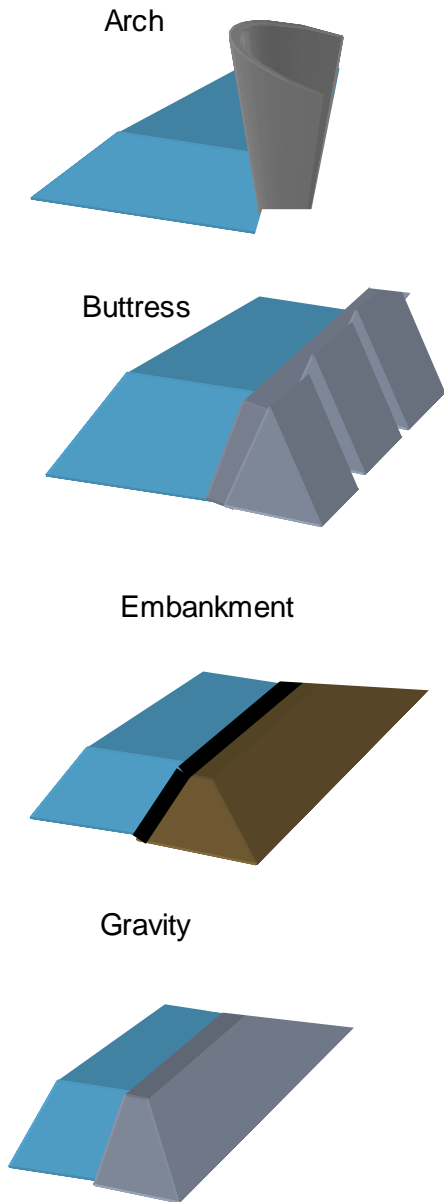

5. Provide tips on building each dam as necessary. The following are some suggestions for successful dams:

- “Arch” dam: cut a rectangular piece of cardboard that is wider than the width of the container. Curve the cardboard and place it in two corners of the container width. This will create a curved wall. The clay and masking tape may be used to seal the seams on the bottom and sides.
- “Buttress” dam: cut out a rectangle of the same width yet taller than the container from recycled cardboard. Cut 2-3 triangles that will support the rectangular wall and secure them with tape. Seal the sides and bottom of the wall to the container with clay or masking tape.
- “Embankment” dam: fill a ziplock bag with soil. Seal the bag and place in the container to fit the width of the container. To seal the seams, adjust the soil to fill any gaps. If required, use more than 1 bag of soil to span the width of the container.
- “Gravity” dam: fill a ziplock bag with rocks and sand and dampen with water (to simulate concrete). Seal the bag and place in the container to span the width of the container. To seal the seams, adjust the sand and rocks to fill any gaps. If required, use more than 1 bag of rock and sand to span the width and apply enough weight to seal any gaps.

5. Test each dam by pouring a cup of water on one side of the container and observe if there is any water seeping through.

6. If water seeps through, then adjust dam accordingly to seal off the leaks with more clay or tape. Record observations for each dam – e.g. what shapes were used in building the dams, how well did it hold the water, how did the force from the water affect the structure and what could be done to improve the dam?

Observations:

Students can observe each of their dams and determine how effective each type of dam was at keeping the water from reaching the other side.

Photo of Sample Construction of the 4 Types of Dams:

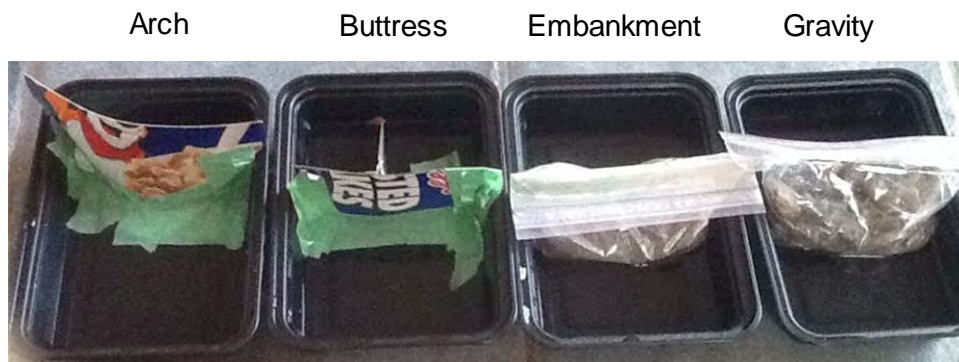

Discussion:

Discuss with students whether they have seen a dam in their community or on their travels. Which dam type did it look like? Ask them to identify the different shapes within the structure. They may have seen arches, rectangular or triangular prisms on the dam. Discuss how the forces from the push of the water are transferred in the different dam structures. The arch dam transfers forces from the semi-circular wall to abutments or valley walls. The buttress dam has a triangular shape which assists in absorbing forces onto the slab of concrete. The embankment and gravity dams resist forces from water by their own weight or the force of gravity.

Some other great resources about dams include:

http://www.icold-cigb.net/GB/Dams/role_of_dams.asp (11/06/15)(International Commission On Large Dams which details role of dams, history and stats on number of dams per country and largest dams)

http://www.imis100ca1.ca/cda/CDA/Dams_In_Canada.aspx(11/06/15)

http://www.britishdams.org/about_dams/types.htm(11/06/15)

Fun Fact: How Big is It?

The world's tallest dam at 335 m (1100 ft) is the Rogun Dam in Tajikistan, built in 1980. It is an embankment dam which means it is filled with earth. The world's biggest dam (the one that used the most material to make) is also an embankment dam. The Syncrude Tailings, in Fort McMurray, Alberta was built in 1992 and although it is only 88 m high, it has the most volume at 540 m³ of earth.

Fun Fact: The Biggest Natural Dam?

The world's largest beaver dam is in Wood Buffalo National Park in northern Alberta. It is over 850 m long! Beavers build these massive structures to create deep pools of water that assist them in floating food and building materials as well as protecting them against predators. Beaver dams are one of the few animal-made structures that are visible from space!



Name: _____

Hold That Water!

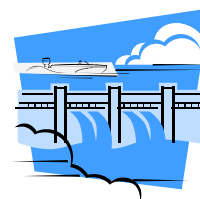

Arch dam	Buttress dam
Observations:	Observations:
Gravity dam	Embankment dam
Observations:	Observations:

Activity 5: Hold It Up!

Time: 60-90 minutes

Other Application: Art

Key Terms: stability, load, centre of gravity, balance, shape, form, function

Group Size: Individual

Materials:

- "Hold It Up!" planning worksheet per student
- recyclable material such as coffee cups, plastic cups, boxes, egg cartons
- straws
- popsicle or stir sticks
- sponges
- construction paper
- large paper clips
- glue
- tape
- paint and brushes
- scissors

Learning Goal: Students will learn about designing and building a strong stable structure.

Engineers consider various elements when designing structures:

- the form or size of the structure;
- the centre of gravity – is it low enough to be able to withstand wind and vibrations (e.g. wide and/or solid base);
- the shapes to use in the structure (e.g. triangles, cylinders and arches).

By considering these types of elements, students will create a structure that can display their artwork and can be an art piece itself. This project can be used to hold their class artwork, as presents for mothers or fathers day, or to hold name tags in the classroom.

Procedure:

1. Ask students to help collect clean recyclable materials for this project. Supply other items such as popsicle/stir sticks, sponges, straws, large paper clips. Create material stations for students that contain a variety of materials to build their project.
2. Provide a goal for this project and identify the purpose of the structure to students. Their structure must be:
 - a strong, stable structure
 - able to hold a 8.5 x 11" sheet of paper for display
 - artfully decorated
 - able to exchange artwork.
3. Have students plan and design their project using the "Hold It Up!" worksheet.
4. Have students create a plan for the structure's design by first noting the different materials available to them at the stations. Have students draw their design on the "Hold It Up!" worksheet. Encourage students to consider how they will design the base, how it will hold art and what design elements they will use.
5. Have students build their structure using items from the material stations and test their structure using some current artwork. Allow students the time to make any necessary improvements on their structure to address any issues discovered during testing.
6. Provide art supplies such as paint and brushes to decorate their structure.



Discussion:

Discuss with students how they approached their design in the planning stages. What elements did they think of for their structure? Why did they choose the materials they used? What challenges did they encounter when building it? How did their structure perform when tested? What improvements did they make?

Name: _____

Hold It Up!



<p>Plan</p>	<p>Write down ideas for your structure:</p> <p>What materials will you use?</p>
<p>Design</p>	<p>What will it look like?</p>

Teacher Resources

Literary Resources

Megastructures. Ian Graham. 2012. Firefly Books. ISBN 978-1-77085-111-5.
A book on all types of structures.

Skyscrapers: Super Structures to Design and Build. 2001. Carol A. Johmann. Williamson Publishing. ISBN 1-885593-50-3. Review of history, planning and construction of skyscrapers and experiments.

Bridges! Amazing structures to design, build & test. 1999. Carol A. Johmann and Elizabeth J. Rieth. Williamson Publishing. ISBN1-885593-30-9. The history of bridges, different types and experiments.

Bridges and Tunnels – Investigate feats of engineering. Donna Latham. 2012. Nomad Press. ISBN 978-1-936749-52-2. A book on engineering bridges and tunnels including projects and experiments.

Website Resources

<http://d21na5cfk0jewa.cloudfront.net/bedrock/event-kit/peep-event-structures.pdf> (27/08/15)
Experiments for building structures.

<http://pbskids.org/zoom/activities/sci/> (11/06/15)
Experiments for making a birds nest, standing on cups, columns, building cup towers, etc.

<http://www.pbs.org/wgbh/buildingbig/bridge/index.html> (11/06/15)
PBS website on different bridges, tunnels, dams, domes, showing forces that act on the structures.

https://www.teachengineering.org/view_lesson.php?url=collection/wpi_/lessons/wpi_forces/wpi_lesson_1.xml (27/08/15) Tension and compression on bridges.

http://www.teachersdomain.org/resource/phy03.sci.phys.mfw.lp_shapes/ (11/06/15)
Experiments on shapes that make structures strong.

<http://www.scholastic.com/teachers/lesson-plan/magic-school-bus-under-construction> (11/06/15)
Experiment making gum drop bridge.

<http://www.mylearning.org/learning/crazy-catapults/Structure%20Strength.pdf> (11/06/15)
Testing different shapes with marshmallow structures.

http://toolboxes.flexiblelearning.net.au/demosites/series10/10_01/content/bcgbc4010a/03_properties/topic_index.htm (11/06/15). A great resource for definition of terms used in the industry.

Interactive Whiteboard Resources

<http://exchange.smarttech.com/details.html?id=6c90739a-84e8-4627-b0e6-9db10be46a22> (21/10/13)
Identifying different types of bridges and parts of bridges.

Multi Media

<http://science.discovery.com/video-topics/engineering-construction/engineering-the-impossible-arches-vs-beams.htm> 1:40 min (21/10/13) Emphasizing load difference on two types of bridges.

https://www.youtube.com/watch?v=c-V_8_qmJbE DSN Animation: What is tension/compression? 0:30min(27/08/15).

Student Resources

Literary Resources

How Tall is Tall? – Comparing Structures. Vic Parker. 2010. Heinemann Library. ISBN 978-1-4329-3955-7. A book that compares heights of different well known structures.

The Big Book of Skyscrapers Gina Ingoglia. 1989. Grosset & Dunlop Inc. ISBN 0-448-19186-5. A book which reviews history of skyscrapers, people involved in constructing, foundation designs and wind protection design.

Earth Friendly Buildings, Bridges and more. Etta Kaner. 2012. Kids Can Press Ltd. ISBN 978-1-55453-570-5. A book that reviews foundations, bridges, tunnels, domes, dams.

Building Amazing Structures series (Skyscrapers, Bridges, Dams, Tunnels). Chris Oxlade. 2000. Heinemann Library. A series of books on how to build different structures.

Interactive Resources

<http://www.sciencekids.co.nz/gamesactivities/materialproperties.html> (11/06/15)

Testing different materials.

<http://www.pbs.org/wgbh/buildingbig/lab> (11/06/15)

Test out different materials, shapes, forces, loads and discover their effect on structures.

<http://kids.discovery.com/games/build-play/build-a-coaster> (11/06/15)

Kids can build their own roller coaster.

<http://www.sciencekids.co.nz/pictures/structures.html> (11/06/15)

Pictures of structures around the world.

<http://www.projects.yrdsb.edu.on.ca/structures> (11/06/15)

Discover everyday structures.

“Fat Birds Build a Bridge!” (10/11/13)

An interesting puzzle game App for Ipad/Ipod for building and testing bridges.

“Link!” (10/11/13)

A game App for Ipad/Ipod that uses principles of civil engineering to create stable structures.

“Bridge Constructor Playground” (10/11/13)

A game App for Ipad/Ipod for building bridges.

Fun Fact: Traditional Tipis!

The traditional tipi, used by First Nations, was an easily assembled, stable and mobile structure. Buffalo skins, that are lightweight and waterproof, were used as a covering.

References

In addition to resources listed above, the following websites were also used to develop this package: <http://courses.washington.edu/cee380/ochsendorf.pdf> (21/10/13); http://www.geostrategis.com/p_beavers-longestdam.htm (02/12/13).



Get kids excited about science

Science Education Through Partnership

Scientists in School is a leading science education charity that reaches more Kindergarten to Grade 8 youth than any other science non-profit in Canada – 703,000 in the 2017-18 school year.

Through our hands-on, inquiry-based science, technology, engineering, math (STEM) and environmental classroom and community workshops, we strive to ignite scientific curiosity in children so that they question intelligently; learn through discovery; connect scientific knowledge to their world; get excited about science, technology, engineering and math; and have their interest in careers in those fields piqued.

By making science a verb - something you do - our workshops allow children's natural curiosity to reign, inspire kids to see themselves as scientists and engineers, and make connections between science and the world around them. This sets the stage for a scientifically-literate future generation who will fuel Canada's economic prosperity and think critically about the scientific challenges facing our society.

Scientists in School relies upon corporate, community, government and individual donors, as well as school board partners for support to develop new programs, continuously improve our existing programs, reach new geographic areas, provide complimentary workshops to less-privileged schools, and subsidize the cost of every one of our 25,040 annual classroom workshops.

Our Partners

Catalyst Level:

Natural Sciences and Engineering Research Council (NSERC), TD Friends of the Environment Foundation, Toronto Pearson International Airport

Innovation Level:

Amgen Canada, John and Deborah Harris Family Foundation, Nuclear Waste Management Organization, Ontario Power Generation, RBC

Imagination Level:

ArcelorMittal Dofasco, General Motors Canada, McMillan LLP, Pure Green Earth Fund, Superior Glove Works Ltd., TELUS

Discovery Level:

Ajax Community Fund at Durham Community Foundation, AtlasCare, Bruce Power, Cameco, Hamilton Community Foundation, MilliporeSigma, Ottawa Community Foundation, pharmaKARe consulting, Purdue Pharma, Syngenta, Systematix Inc., The Johansen-Larson Foundation, The McLean Foundation, The Township of Tiny, Waste Management

Exploration Level:

Brampton and Caledon Community Foundation, Brockville and Area Community Foundation, City of Brantford, Guelph Community Foundation, Huronia Community Foundation, Jackman Foundation, Lee Valley Tools, Niagara Community Foundation, Ontario Teachers Insurance Plan (OTIP), Rotary Club of Lethbridge Sunrise, Siemens Milltronics Process Instruments, The Source, Veridian Connections, Whitby Mayor's Community Development Fund, Youngs Insurance Brokers Inc.